

SPARTAN FIRE, LLC.
EPHRATA, PA 17522

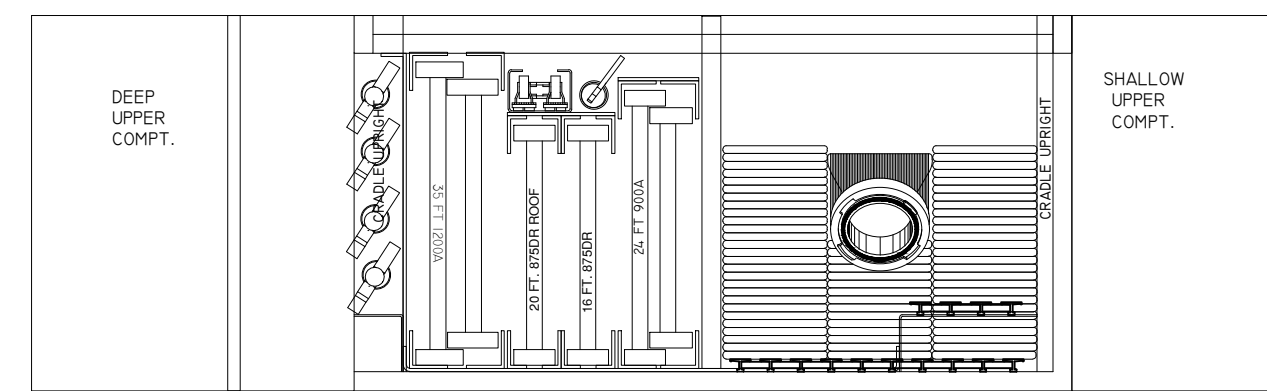
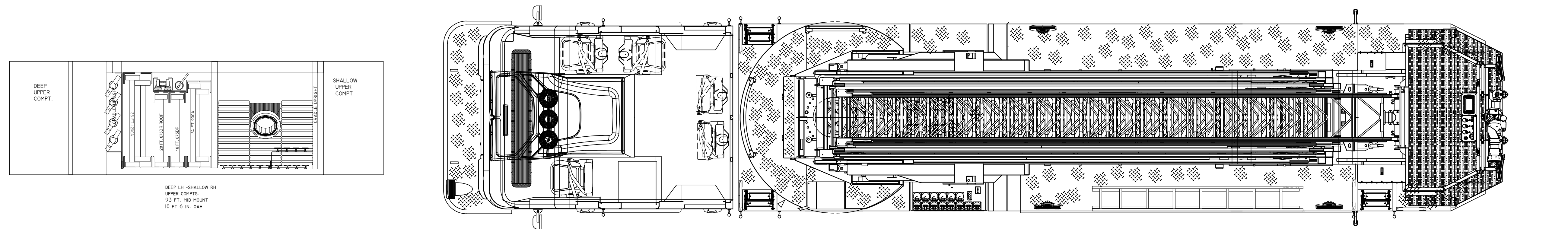

DEEP LH - SHALLOW RH
UPPER COMPT.
93 FT. HD-MOUNT
10 FT 6 IN. GAH

CHASSIS:
SPARTAN GLADIATOR MFD 10" RAISED ROOF

ENGINE:
CUMMINS X-15 605 HP

TRANSMISSION:
ALLISON 4000 EVS

AXLES:
23,000# FRONT / 62,000# REAR

MODEL:
P45M-93 LADDER TOWER

WATER/FOAM:
300 WATER / NO FOAM

PUMP:
HALE 8FG 2000 GPM (RATED 1750 GPM)

FOAM SYSTEM:
N/A

GENERATOR:
N/A

COMPARTMENT DIMENSIONS

I.D.	FRAME OPENING	INTERIOR DIMENSIONS
L1	36.00"W x 38.25"H	39.75"W x 43.25"H x 23.00"D
L2	54.00"W x 25.00"H	63.25"W x 27.25"H x 24.00"D
L3	54.00"W x 25.00"H	60.25"W x 27.50"H x 24.00"D
L4	48.00"W x 52.25"H	52.50"W x 57.25"H x 24.00"D
L5	22.50"W x 31.25"H	28.50"W x 35.25"H x 13.00"D
R1	36.00"W x 38.25"H	39.75"W x 43.25"H x 23.00"D
R2	54.00"W x 25.00"H	63.25"W x 29.00"H x 13.50"D
R3	54.00"W x 25.00"H	60.25"W x 29.00"H x 13.50"D
R4	48.00"W x 52.25"H	52.50"W x 57.25"H x 13.50"D
R5	41.75"W x 31.25"H	48.75"W x 35.25"H x 13.00"D

GROUND LADDER INVENTORY:
ONE DUO-SAFETY 35 FT. 1200A 2-SECTION
ONE DUO-SAFETY 24 FT. 900A 2-SECTION
ONE DUO-SAFETY 20 FT. 875A ROOF
ONE DUO-SAFETY 16 FT. 875A ROOF
ONE DUO-SAFETY 10 FT. 585A FOLDING
ONE DUO-SAFETY 14 FT. 775A IN AERIAL FLY
ONE DUO-SAFETY 14 FT. 701 FRESNO LADDER ON TOP OF BODY
TWO FHU APH-8 ALL PURPOSE HOOKS
TWO FHU APH-6 ALL PURPOSE HOOKS
ONE FHU NY-10 PIKE POLE
ONE FHU NY-12 PIKE POLE IN FLY SECTION

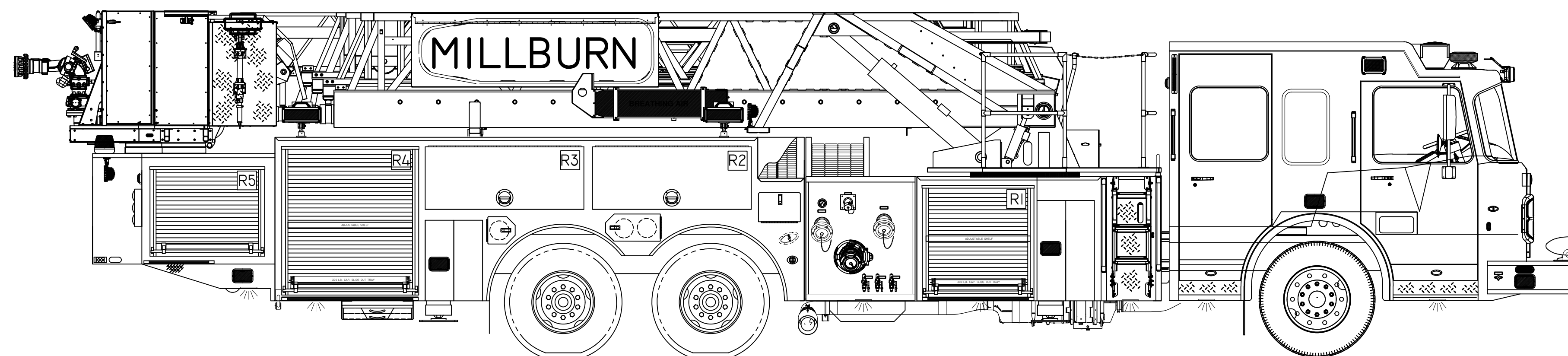
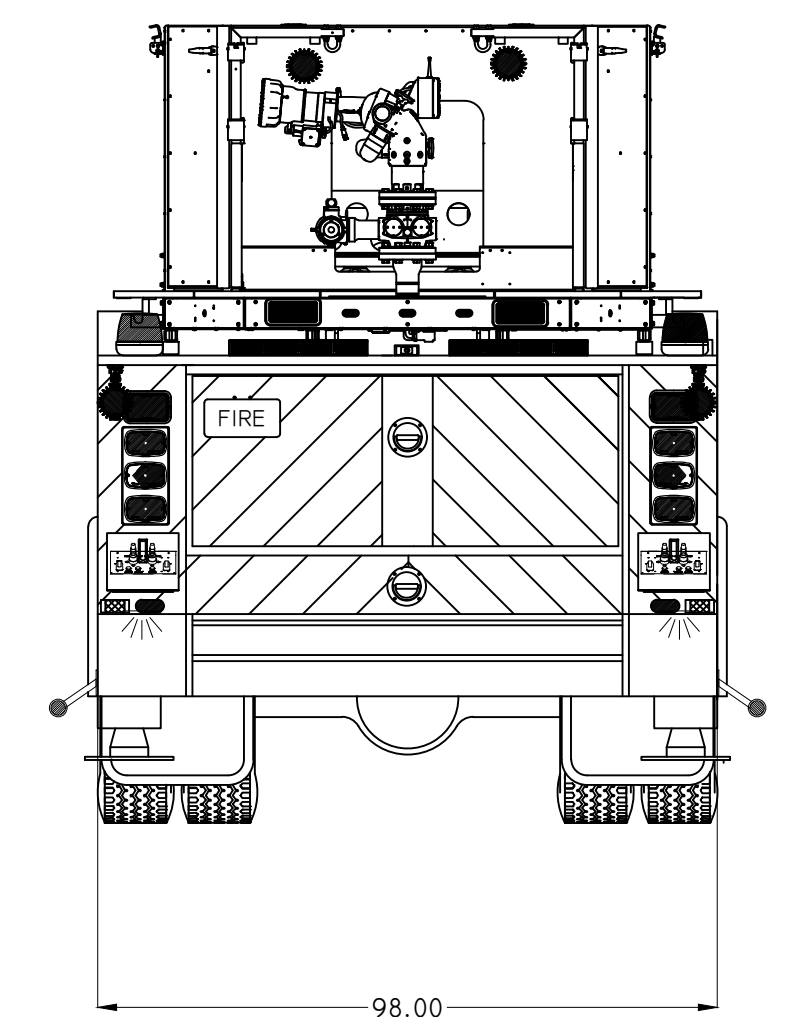
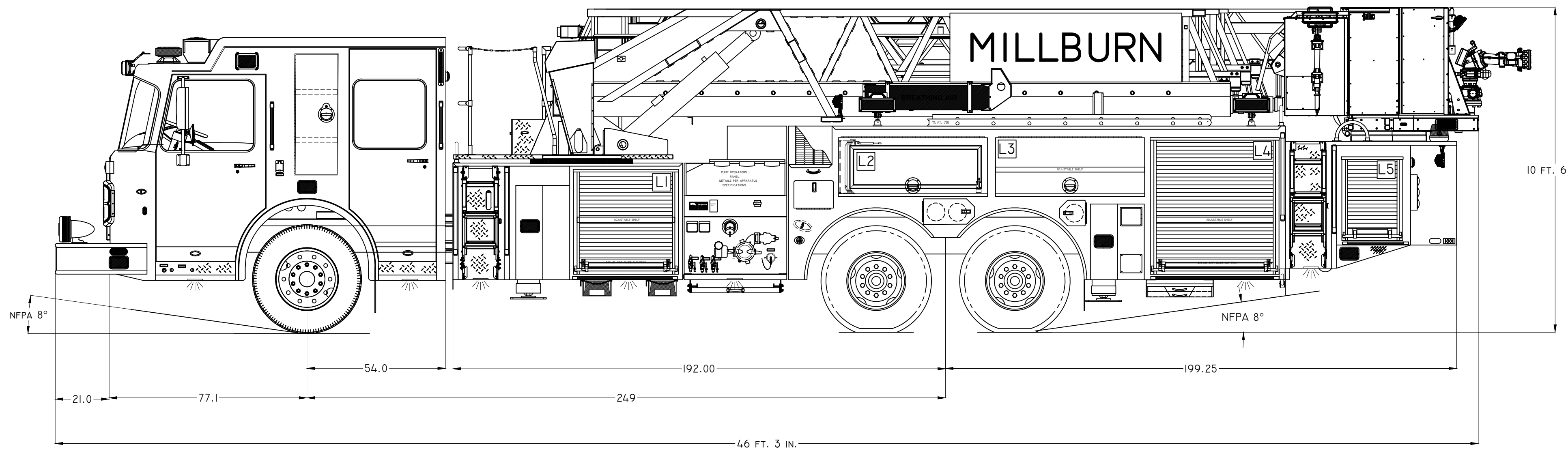
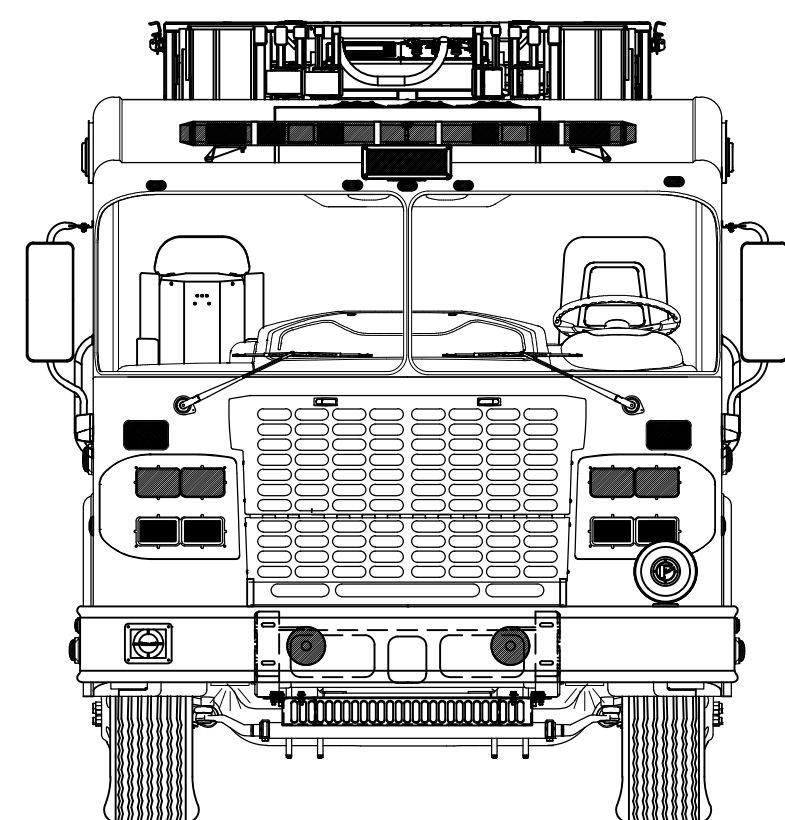

CUSTOMER

THIS DRAWING IS A CLOSE APPROXIMATION OF YOUR FIRE APPARATUS. IN ALL CASES WHERE THE DRAWING AND THE WRITTEN SPECIFICATION DIFFER, THE SPECIFICATION SHALL PREVAIL. PLEASE WORK WITH YOUR DEALER TO ASSURE THAT THE WRITTEN SPECIFICATION REPRESENTS WHAT YOU WANT IN YOUR FINISHED PRODUCT. SPARTAN FIRE, LLC BUILDS TO THE WRITTEN SPECIFICATION, NOT THE DRAWING TO ASSURE THAT YOUR NEEDS ARE MET.

PROPRIETARY AND CONFIDENTIAL
THE INFORMATION CONTAINED IN THIS DRAWING IS THE SOLE PROPERTY OF SPARTAN FIRE, LLC. ANY REPRODUCTION IN PART OR AS A WHOLE WITHOUT THE WRITTEN PERMISSION OF SPARTAN EMERGENCY RESPONSE IS PROHIBITED. SPARTAN MOTORS USA, INC. D/B/A SPARTAN FIRE, LLC.

REV	DATE	DESCRIPTION	NAME
1	6/12/22	CHANGED CAB-EMFD(60") WAS LFD(67.5")	WB
0	5/15/22	INITIAL PROPOSAL	WB

SCALE: NOT TO SCALE

MILLBURN FIRE DEPARTMENT
MILLBURN, NEW JERSEY

TRUCK NUMBER:
000000

DRAWING No.
3-020-0385