

SPARTAN FIRE, LLC.
 EPHRATA, PA 17522

CHASSIS: SPARTAN GLADIATOR EMFD
 ENGINE: CUMMINS XI5 605 HP
 TRANSMISSION: ALLISON 4000 EVS
 AXLES: 24,000 LB. FRONT/58,000 LB. REAR
 MODEL: C34R-110 AERIAL LADDER
 WATER/FOAM: 465 GAL. WATER/ 25 GAL. FOAM
 PUMP: WATEROUS CSU-2000 GPM
 WATEROUS ECLIPSE COMPRESSED AIR FOAM SYSTEM
 GENERATOR: 10 kW ONAN HYDRAULIC

COMPARTMENT DIMENSIONS

I.D.	FRAME OPENING	INTERIOR DIMENSIONS
L1	23.50W x 19.62H	23.63W x 21.25H x 25.50D
L2	36.63W x 67.25H	36.88W x 70.75H x 24.87D
L3	55.25W x 37.25H	55.50W x 40.62H x 24.87D
L4	55.25W x 29.00H	55.50W x 32.37H x 24.00D
L5	44.00W x 58.12H	44.25W x 59.25H x 24.00D
R1	23.50W x 19.62H	23.63W x 21.25H x 25.50D
R2	36.63W x 67.25H	36.88W x 70.75H x 24.87D
R3	55.25W x 37.25H	55.50W x 40.62H x 24.87D
R4	44.00W x 25.62H	44.25W x 30.00H x 24.00D
U	12.25W x 28.62H	12.25W x 28.62H x 12.50D

GROUND LADDERS:
 ONE DUO-SAFETY 35 FT. 1200A 2-SECTION
 ONE DUO-SAFETY 28 FT. 1200A 2-SECTION
 ONE DUO-SAFETY 24 FT. 900A 2-SECTION
 ONE DUO-SAFETY 18 FT. 875DR ROOF
 ONE DUO-SAFETY 16 FT. 875DR ROOF
 ONE DUO-SAFETY 14 FT. 775DR ROOF
 ONE DUO-SAFETY 10 FT. 585A FOLDING
 ONE DUO-SAFETY 14 FT. 775DR ON AERIAL
 ONE DUO-SAFETY 16 FT. 875DR ON AERIAL
 ONE LITTLE GIANT MODEL 13 VELOCITY
 TWO FHU RH-12 ROOF HOOKS
 TWO FHU RH-10 ROOF HOOKS
 TWO FHU RH-8 ROOF HOOKS
 TWO FHU RH-6 ROOF HOOKS
 ONE FHU RH-6 ROOF HOOK IN FLY SECTION

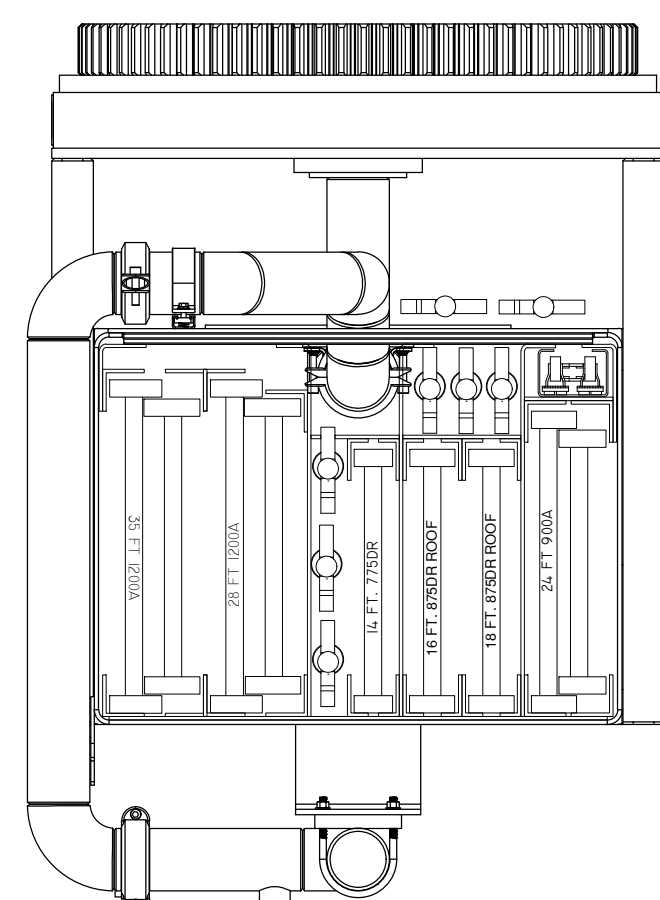

GROUND LADDERS

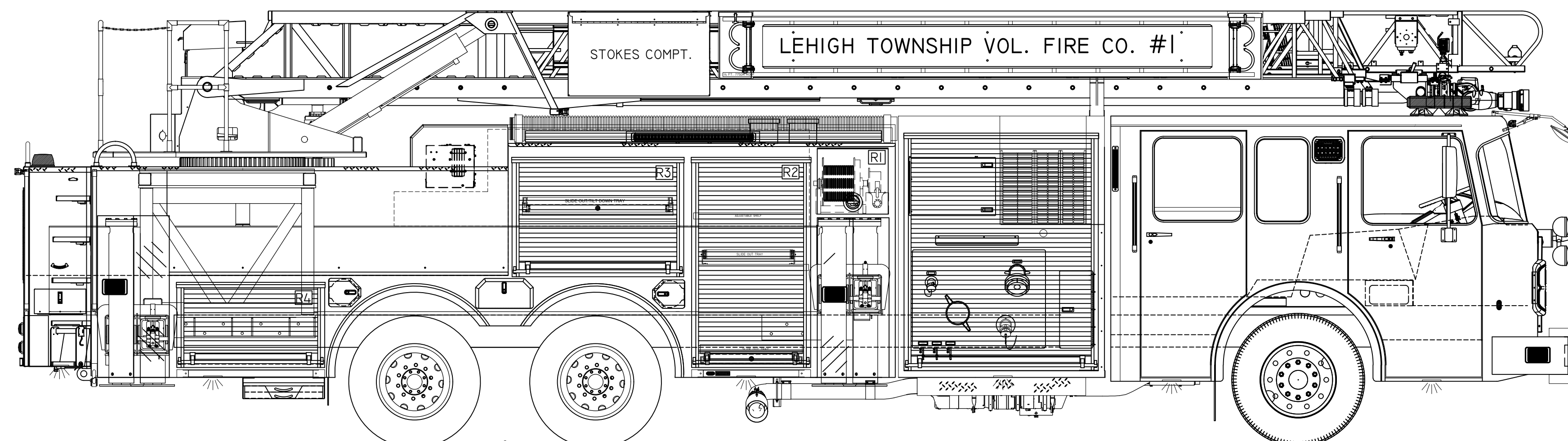
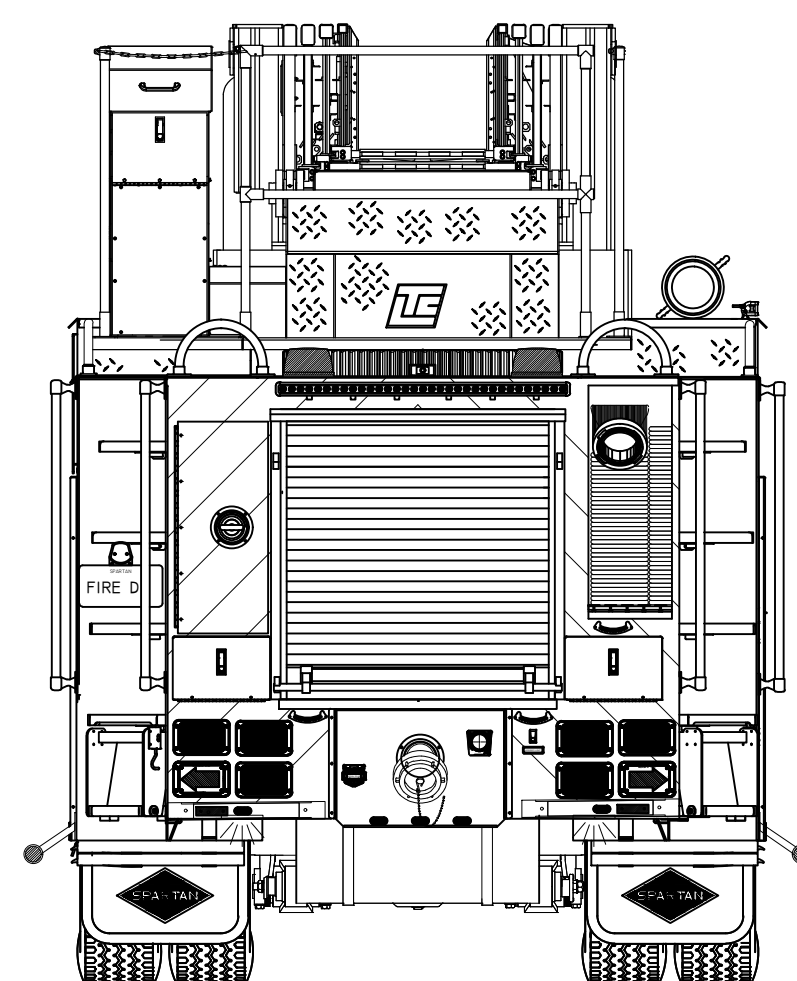
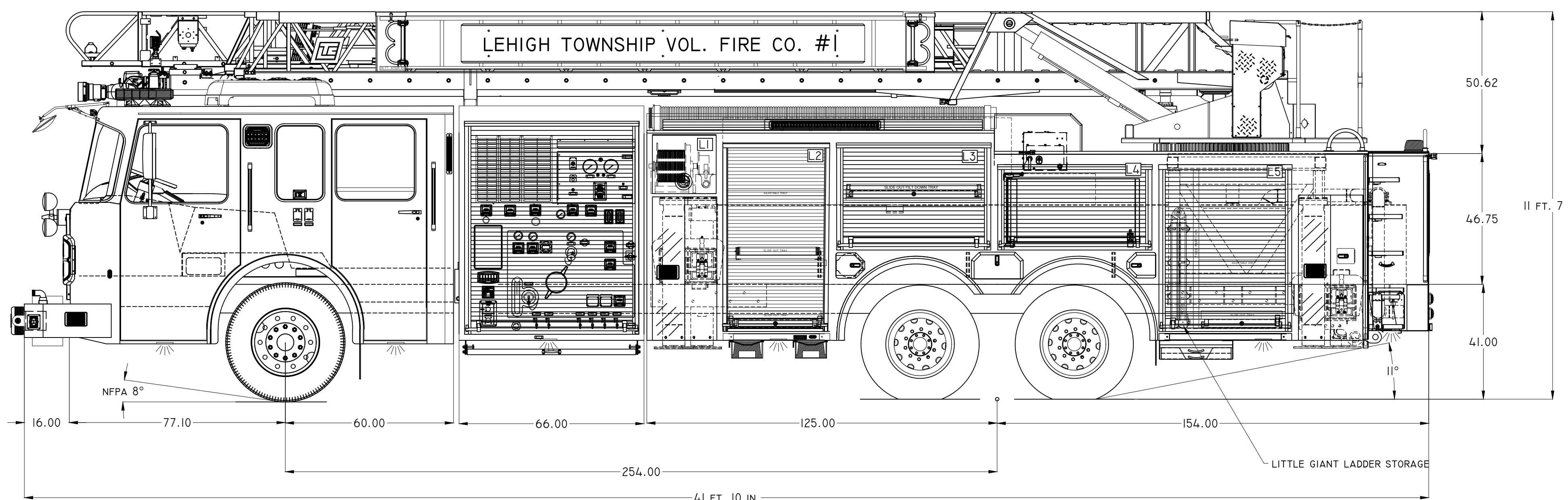
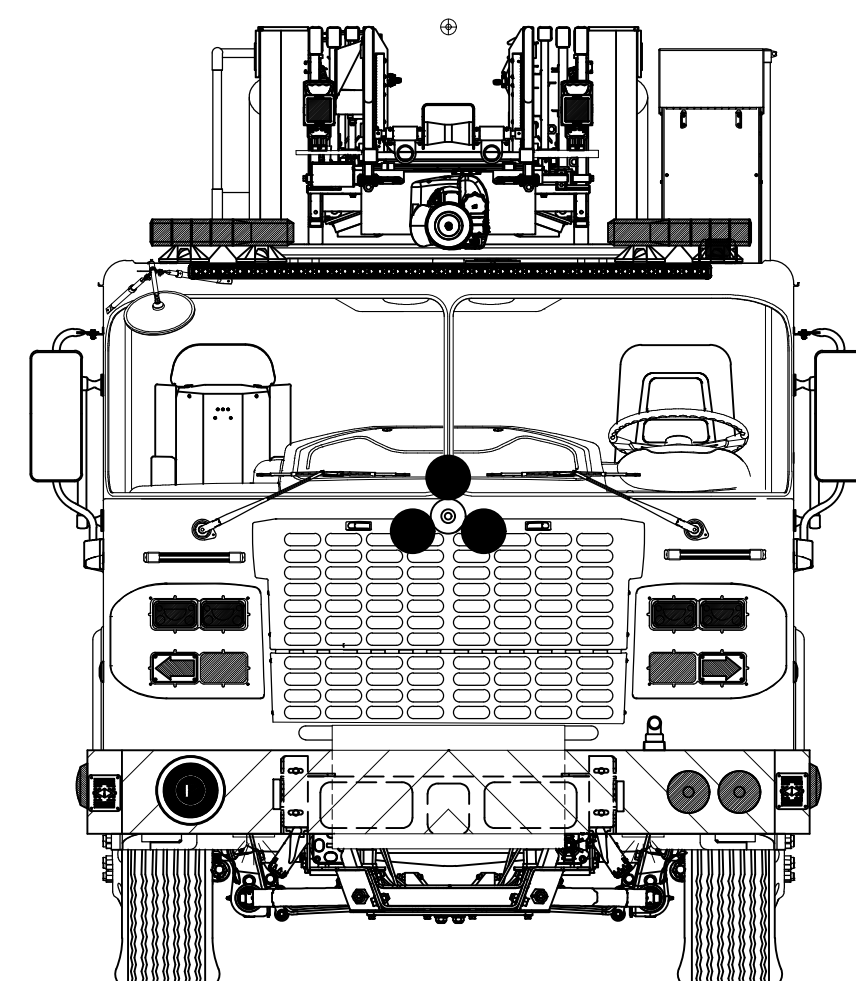
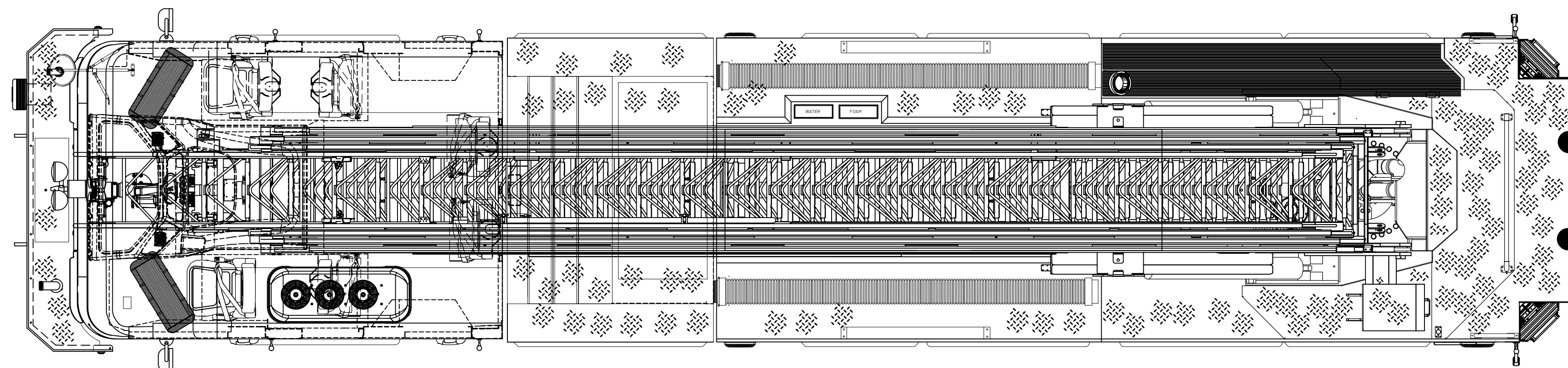

CUSTOMER

PROPRIETARY AND CONFIDENTIAL
 THE INFORMATION CONTAINED IN THIS DRAWING IS THE SOLE PROPERTY OF SPARTAN EMERGENCY RESPONSE. ANY REPRODUCTION IN PART OR AS A WHOLE WITHOUT THE WRITTEN PERMISSION OF SPARTAN EMERGENCY RESPONSE IS PROHIBITED. SPARTAN MOTORS USA, INC. D/B/A SPARTAN EMERGENCY RESPONSE.

THIS DRAWING IS A CLOSE APPROXIMATION OF YOUR FIRE APPARATUS. IN ALL CASES WHERE THE DRAWING AND THE WRITTEN SPECIFICATION DIFFER, THE SPECIFICATION SHALL PREVAIL. PLEASE WORK WITH YOUR DEALER TO ASSURE THAT THE WRITTEN SPECIFICATION REPRESENTS WHAT YOU WANT IN YOUR FINISHED PRODUCT. SPARTAN EMERGENCY RESPONSE BUILDS TO THE WRITTEN SPECIFICATION, NOT THE DRAWING TO ASSURE THAT YOUR NEEDS ARE MET.

REV	DATE	DESCRIPTION	NAME
10	3/6/23	MARK-UP FROM SALES REP.	WB
9	3/2/23	CORRECTED LIGHTBAR ORIENTATION	WB
8	2/28/23	FACTORY SPECIFICATION REVIEW	WB
7	10/27/22	FLAT ROOF CAB WAS 10" RAISED ROOF CAB	WB
6	9/27/22	MINOR DEVELOPMENTAL REVISIONS	WB
5	9/21/22	SECOND REVIEW-QUOTEWRITER FILE AND SPARCON FILE	WB
4	9/7/22	CHANGED OUT LADDER ASSY TO NEW SOLIDWORKS MODEL	WB
3	8/30/22	REVISED GROUND LADDER PKG TO MATCH QUOTEWRITER FILES	WB
2	8/28/22	REVISED TO MATCH SPARCON AND QUOTEWRITER FILES	WB
1	7/28/22	INITIAL DRAWING-NO SPARCON NO QUOTEWRITER	WB

SCALE: NOT TO SCALE

 LEHIGH TOWNSHIP VOL. FIRE CO. #1
 CHERRYVILLE, PENNSYLVANIA

TRUCK NUMBER:

3-012-0134